

# Chapter 1.

## Trigonometry.

### Situation.

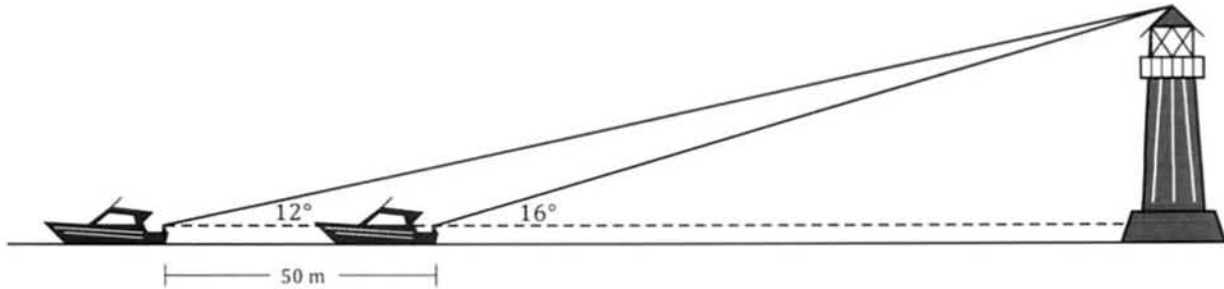

- A person sitting on a boat
- is situated 2 metres above sea level,
  - has a device for measuring angles,
- and
- notes that a straight line from themselves to the top most point of a nearby lighthouse makes an angle of  $16^\circ$  with the horizontal.

After travelling a further 50 metres directly away from the lighthouse this angle has decreased to  $12^\circ$ .

How high is the top most point of the lighthouse above sea level?

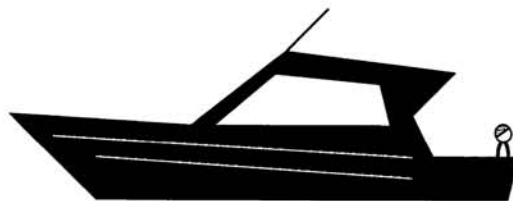
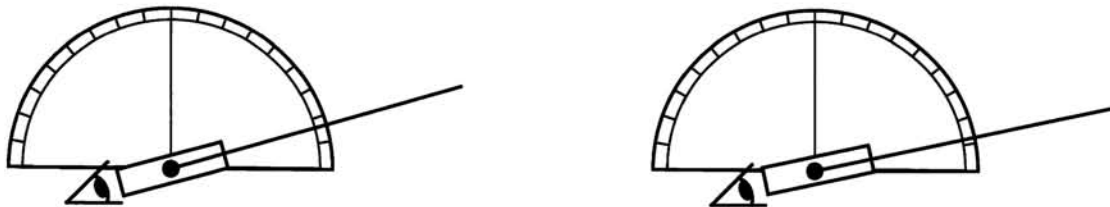

How did you get on with the situation on the previous page?

Perhaps you applied trigonometry to the two right angled triangles and then solved the two equations this approach gave you.

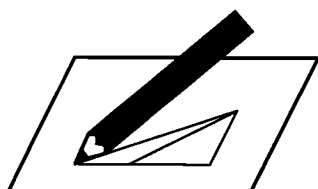
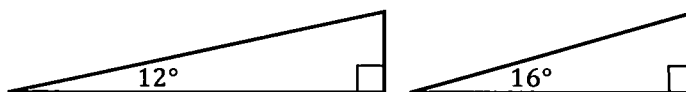

Perhaps you made a scale drawing and measured lengths from that.

Perhaps you have encountered the sine rule in earlier mathematical studies and applied that.

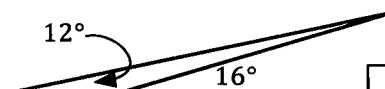

The Preliminary work stated that an ability to apply the trigonometrical ratios of sine, cosine and tangent to right angled triangles was assumed. In this chapter we will consider applying these ratios to triangles that are not right angled.

We will develop three formulae that can be applied to any triangles, right angled or not.

- We will consider:
- a formula for the area of a triangle,
  - the sine rule formula,
  - the cosine rule formula.

However we do have a problem:

Some non right angled triangles will involve obtuse angles but from our right triangle definition of the sine of an angle, i.e.

$$\sin x^\circ = \frac{\text{opposite}}{\text{hypotenuse}}$$

the idea of the sine of an angle bigger than  $90^\circ$  is meaningless because, in a right triangle, we cannot have angles bigger than  $90^\circ$ .

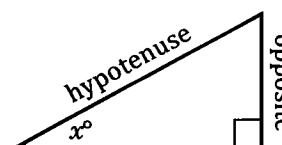

However, values for the sine and cosine of obtuse angles can be obtained from a calculator, as shown on the right.

Thus before we can use trigonometric ratios in triangles that might involve obtuse angles we need to consider what we mean by expressions like

$\sin 95^\circ$ ,  $\sin 150^\circ$ ,  $\cos 100^\circ$ ,  $\cos 170^\circ$  etc.

$\sin 95$	0.9961946981
$\sin 150$	0.5
$\cos 100$	-0.1736481777
$\cos 170$	-0.984807753

**The sine of an angle bigger than 90° – unit circle definition.**

The table below shows values for  $\sin x^\circ$ , as obtained from a calculator and rounded to two decimal places, for  $x$  from 0 to 90 in steps of 10.

$x$	0	10	20	30	40	50	60	70	80	90
$\sin x^\circ$ (2 dp)	0	0.17	0.34	0.50	0.64	0.77	0.87	0.94	0.98	1.00

If we are to redefine the sine of an angle to accommodate angles outside of  $0^\circ$  to  $90^\circ$  it makes sense to require that for angles between  $0^\circ$  and  $90^\circ$  any new definition gives the same values as our right triangle definition gives. Also we need any new definition to be useful, otherwise it simply will not "stand the test of time".

The definition of the sine and cosine of an angle that meets both of these requirements, i.e. it is consistent with the right triangle definition and it proves to be useful in its own right, is the **unit circle definition**.

The diagram on the right shows a circle centre  $O$  and of unit radius (i.e. a unit circle).

Point  $A$  is initially at location  $(1, 0)$  and the line  $OA$ , fixed at  $O$ , is rotated anticlockwise.

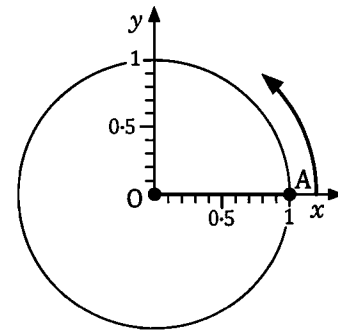

**The sine of the angle that  $AO$  makes with the positive  $x$ -axis is given by the  $y$ -coordinate of  $A$ .**

Thus for angles of  $25^\circ$ ,  $130^\circ$  and  $160^\circ$  consider  $OA$  rotating to the positions shown in the diagrams below.

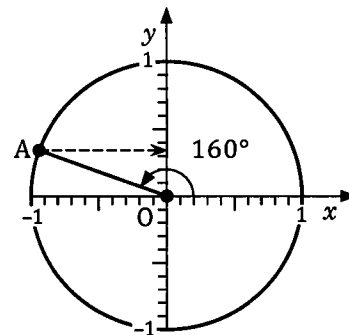
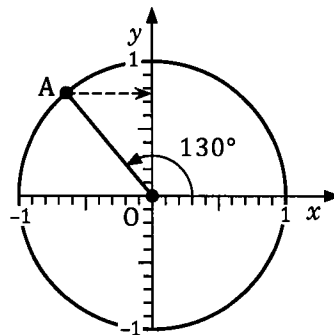
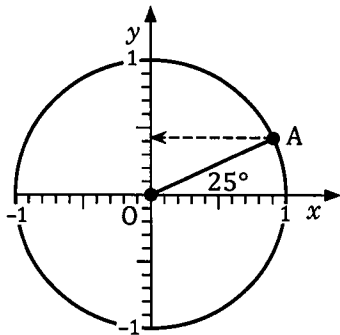

In each case the sine of the angle that  $AO$  makes with the positive  $x$ -axis is given by the  $y$ -coordinate of  $A$ . Thus:

$$\sin 25^\circ \approx 0.42$$

$$\sin 130^\circ \approx 0.77$$

$$\sin 160^\circ \approx 0.34$$

Use the following diagrams to estimate values for  $\sin 50^\circ$ ,  $\sin 120^\circ$  and  $\sin 165^\circ$  and then compare your answers to the values your calculator gives.

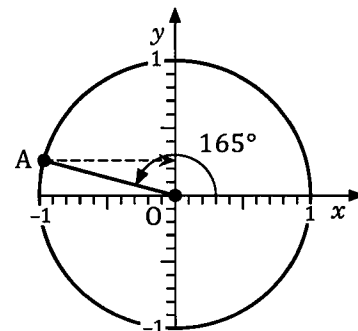
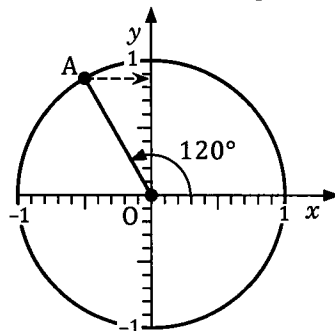
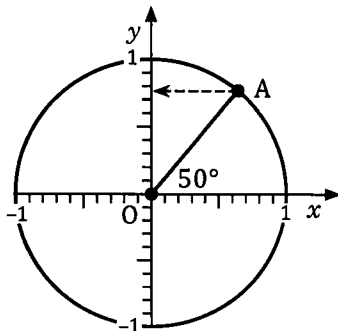

Notice that for angles from  $0^\circ$  to  $90^\circ$  this unit circle definition for the sine of an angle gives exactly the same value as the right angled triangle definition.

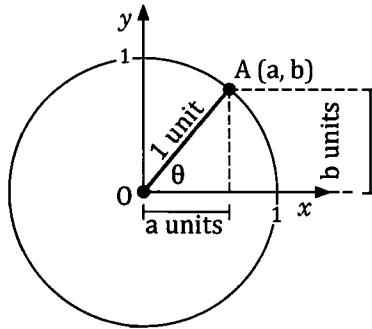

Note •  $\theta$  ("theta") is a Greek letter commonly used to represent angles.

**By the unit circle definition.**

$$\begin{aligned} \sin \theta &= \text{the } y\text{-coordinate of } A \\ &= b \end{aligned}$$

**By the right triangle definition.**

$$\begin{aligned} \sin \theta &= \frac{\text{opposite}}{\text{hypotenuse}} \\ &= \frac{b}{1} \\ &= b \end{aligned}$$

Note also that from this unit circle definition, the sine of an obtuse angle is the same as the sine of its supplement. i.e. if  $A$  is an obtuse angle then

$$\sin A = \sin (180^\circ - A)$$

For example

$$\begin{aligned} \sin 155^\circ &= \sin (180^\circ - 155^\circ) \\ &= \sin 25^\circ \end{aligned}$$

$$\begin{aligned} \sin 130^\circ &= \sin (180^\circ - 130^\circ) \\ &= \sin 50^\circ \end{aligned}$$

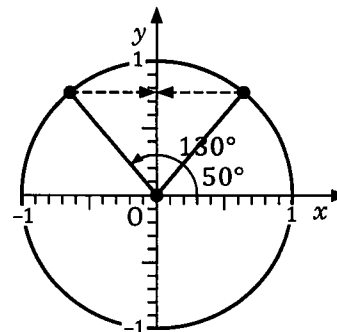
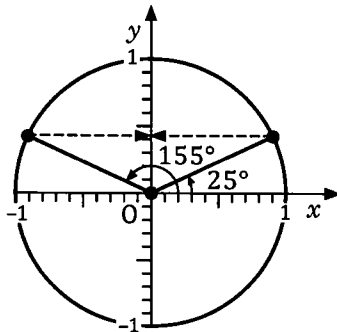

**The cosine of an angle bigger than  $90^\circ$  - unit circle definition.**

The diagram on the right shows a circle centre  $O$  and of unit radius.

Point  $A$  is initially at location  $(1, 0)$  and the line  $OA$ , fixed at  $O$ , is rotated anticlockwise.

**The cosine of the angle  $AO$  makes with the positive  $x$ -axis is given by the  $x$ -coordinate of  $A$ .**

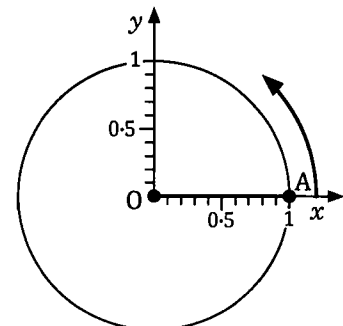

Once again, for angles of  $0^\circ$  to  $90^\circ$  this unit circle definition for the cosine of an angle gives exactly the same value as the right angled triangle definition:

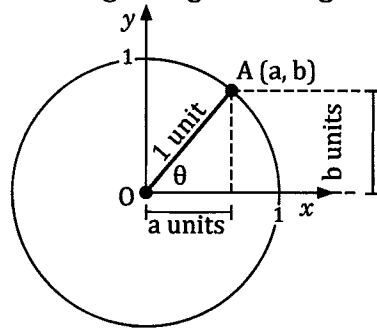

**By the unit circle definition.**

$$\begin{aligned} \cos \theta &= \text{the } x\text{-coordinate of } A \\ &= a \end{aligned}$$

**By the right triangle definition.**

$$\begin{aligned} \cos \theta &= \frac{\text{adjacent}}{\text{hypotenuse}} \\ &= \frac{a}{1} \quad \text{i.e. } a \end{aligned}$$

From this unit circle definition we can see from the diagrams below that:

$$\cos 35^\circ \approx 0.82$$

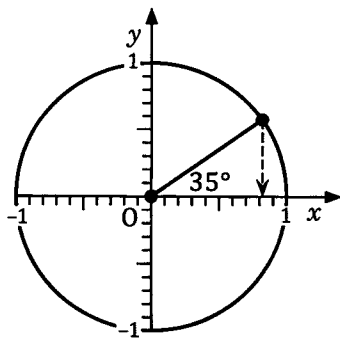

$$\cos 120^\circ \approx -0.5$$

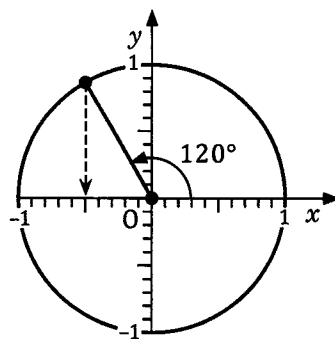

$$\cos 145^\circ \approx -0.82$$

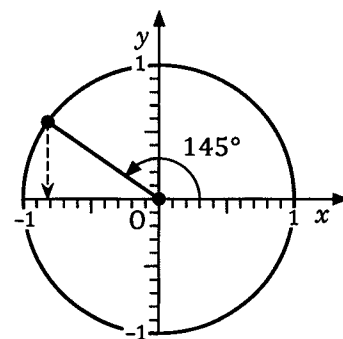

Note also that from this unit circle definition, the cosine of an obtuse angle is the negative of the cosine of its supplement. i.e. if  $A$  is an obtuse angle then

$$\cos A = -\cos (180^\circ - A)$$

For example

$$\begin{aligned} \cos 155^\circ &= -\cos (180^\circ - 155^\circ) \\ &= -\cos 25^\circ \end{aligned}$$

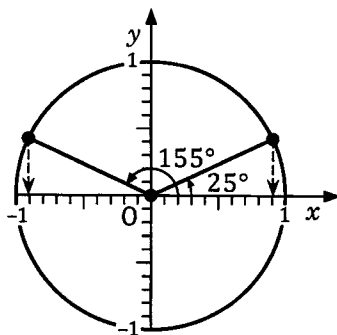

$$\begin{aligned} \cos 130^\circ &= -\cos (180^\circ - 130^\circ) \\ &= -\cos 50^\circ \end{aligned}$$

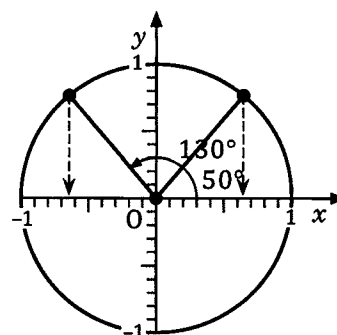

**Exercise 1A.**

Use the unit circle diagram shown below right to determine each of the following and, in each case, check the reasonableness of your answer by comparing it with the value given by your calculator.

1.  $\sin 0^\circ$
2.  $\sin 32^\circ$
3.  $\sin 57^\circ$
4.  $\sin 75^\circ$
5.  $\sin 90^\circ$
6.  $\sin 108^\circ$
7.  $\sin 148^\circ$
8.  $\sin 155^\circ$
9.  $\sin 180^\circ$

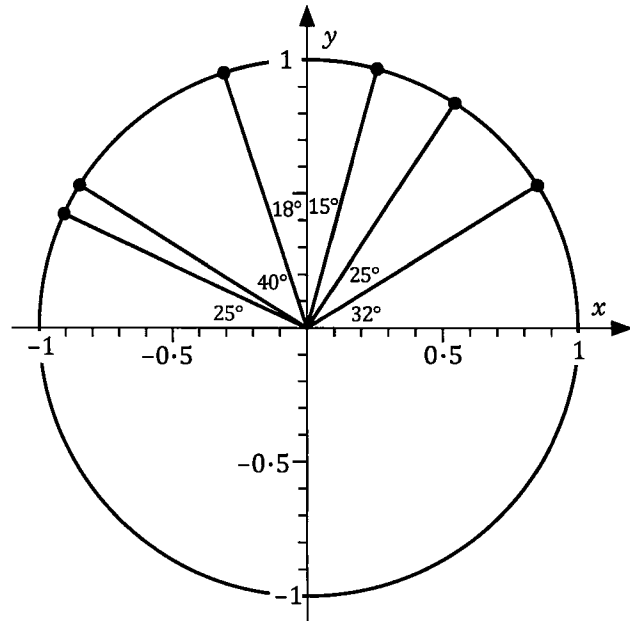

Use the unit circle diagram shown below right to determine each of the following and, in each case, check the reasonableness of your answer by comparing it with the value given by your calculator.

10.  $\cos 0^\circ$
11.  $\cos 20^\circ$
12.  $\cos 50^\circ$
13.  $\cos 70^\circ$
14.  $\cos 90^\circ$
15.  $\cos 160^\circ$
16.  $\cos 180^\circ$
17.  $\cos 110^\circ$
18.  $\cos 130^\circ$

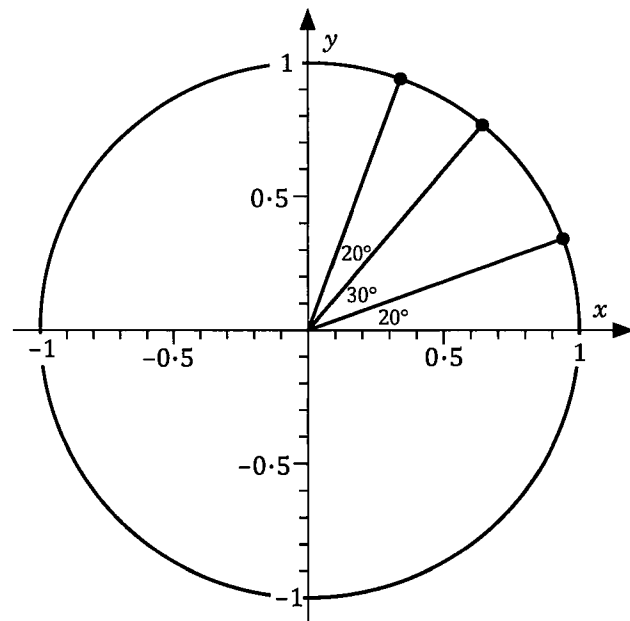

**Area of a triangle given two sides and the angle between them.**

Suppose we have a triangle ABC and we know the lengths of two sides and the size of the angle between these sides, as shown below left for an acute angled triangle and below right for an obtuse angled triangle.

Acute angled triangle

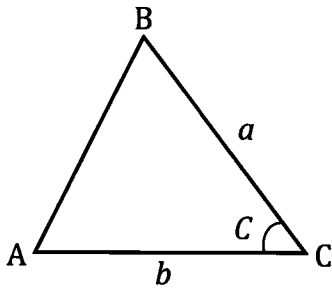

Obtuse angled triangle

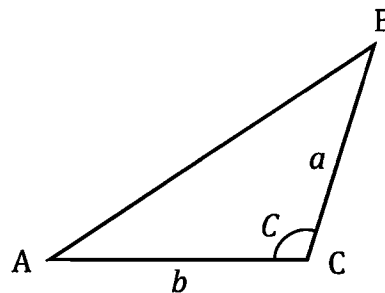

Draw the perpendicular from B to meet AC at D:

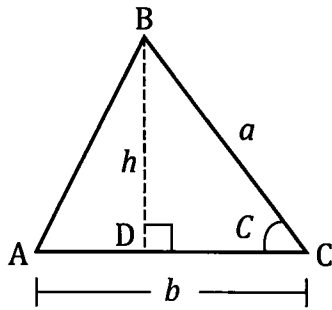

In  $\triangle BDC$ ,  $\sin C = \frac{h}{a}$   
 Thus  $h = a \sin C$   
 $\therefore$  Area  $\triangle ABC = \frac{1}{2}$  base  $\times$  height  
 $= \frac{1}{2} \times b \times a \sin C$   
 $= \frac{ab \sin C}{2}$

Draw the perpendicular from B to meet AC produced at D:

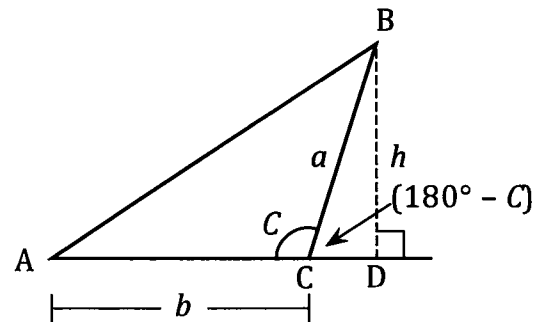

$\sin (180^\circ - C) = \frac{h}{a}$   
 i.e.  $\sin C = \frac{h}{a}$   
 Thus  $h = a \sin C$   
 Hence: Area  $\triangle ABC = \frac{1}{2} \times b \times a \sin C$   
 $= \frac{ab \sin C}{2}$

Thus for both acute and obtuse angled triangles:

$$\text{Area} = \frac{ab \sin C}{2}$$

i.e.: **The area of a triangle is half the product of two sides multiplied by the sine of the angle between them.**

**Example 1**

Find the area of the triangle shown sketched on the right.

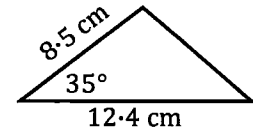

$$\begin{aligned} \text{Area} &= \frac{12.4 \times 8.5 \times \sin 35^\circ}{2} \\ &\approx 30.23 \text{ cm}^2 \end{aligned}$$

The area of the triangle is 30.2 cm<sup>2</sup>, correct to one decimal place.

**Example 2**

Find the area of the triangle shown sketched on the right.

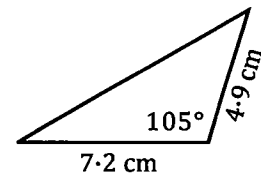

$$\begin{aligned} \text{Area} &= \frac{7.2 \times 4.9 \times \sin 105^\circ}{2} \\ &\approx 17.04 \text{ cm}^2 \end{aligned}$$

The area of the triangle is 17.0 cm<sup>2</sup>, correct to one decimal place.

**Example 3**

If each of the triangles shown below have an area of 7 cm<sup>2</sup> find  $x$  correct to one decimal place in each case.

(a)

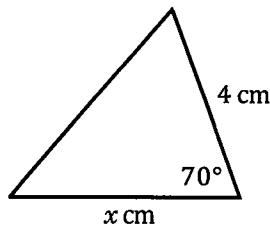

(b)

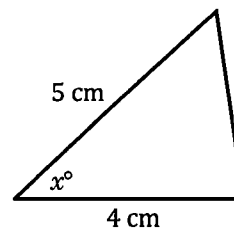

(a) Area =  $\frac{1}{2} (x) 4 \sin 70^\circ$

$\therefore 7 = \frac{1}{2} (x) 4 \sin 70^\circ$

i.e.  $7 = 2x \sin 70^\circ$

Solving this equation gives

$x = 3.7$ , correct to 1 d.p.

(b) Area =  $\frac{1}{2} (4) (5) \sin x^\circ$

$\therefore 7 = \frac{1}{2} (4) (5) \sin x^\circ$

i.e.  $7 = 10 \sin x^\circ$

Solving this equation gives

$x = 44.4$  or  $135.6$ , correct to 1 d.p.



Note that for part (b) we had to give two answers because there are two possible values of  $x$ , in the range  $0$  to  $180$ , for which  $\sin x^\circ = 0.7$ . For one of these values  $x^\circ$  is an acute angle ( $44.4^\circ$ ) and for the other  $x^\circ$  is obtuse ( $180^\circ - 44.4^\circ = 135.6^\circ$ ).

Alternatively we could use the solve facility of some calculators to determine the answers to each part of the previous example, as shown on the right.

Note especially how both answers have been obtained for part (b) by instructing the calculator to solve for  $x$  in the interval  $0 \leq x \leq 180$ .

$$\text{solve}(7=2x \sin(70), x)$$

$$\{x = 3.724622204\}$$

$$\text{solve}(7=10 \sin(x), x) | 0 \leq x \leq 180$$

$$\{x = 44.427004, x = 135.572996\}$$

The two solutions are shown below.

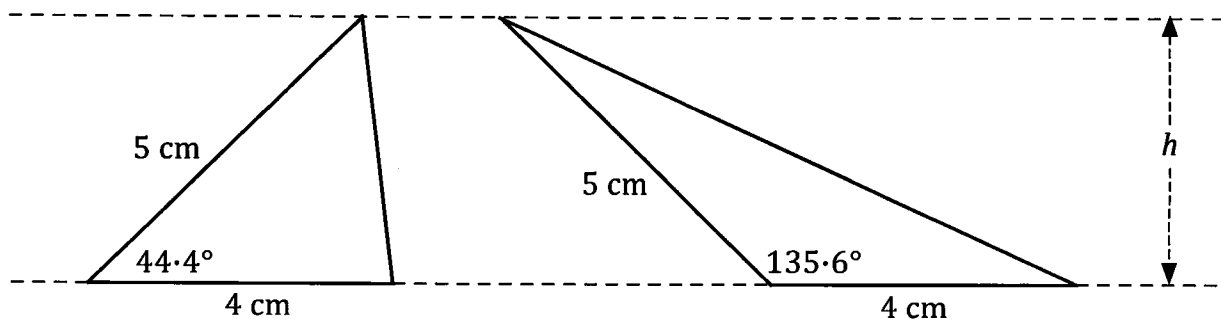

$$\text{Area} = \frac{1}{2} (4) (5) \sin 44.4^\circ$$

$$\approx 7 \text{ cm}^2$$

$$\text{Area} = \frac{1}{2} (4) (5) \sin 135.6^\circ$$

$$\approx 7 \text{ cm}^2$$

(Note that each triangle has the same length base, 4 cm, and the same height,  $h$ , and so must have identical areas, in this case  $7 \text{ cm}^2$ .)

When dealing with right triangles we knew that when needing to solve an equation like  $\sin x^\circ = 0.7$ , the only applicable solution was the one for  $x$  in the range  $0$  to  $90$ .

With triangles that are not right angled we must be alert to the fact that an equation of the form  $\sin x = c$  can have one solution for  $x$  in the range  $0$  to  $90$  and another in the range  $90$  to  $180$ .

### Exercise 1B

- Find  $x$  in each of the following given that it is an acute angle. (Give your answer correct to the nearest degree.)
  - $\sin x = 0.4$
  - $\sin x = 0.75$
  - $\sin x = 0.8$
- Find  $x$  in each of the following given that it is an obtuse angle. (Give your answer correct to the nearest degree.)
  - $\sin x = 0.2$
  - $\sin x = 0.3$
  - $\sin x = 0.55$
- Given that  $x$  is between  $0^\circ$  and  $180^\circ$  state the two possible values  $x$  can take. (Give your answer correct to the nearest degree.)
  - $\sin x = 0.5$
  - $\sin x = 0.15$
  - $\sin x = 0.72$

Find the areas of each of the following triangles (not necessarily drawn to scale), giving your answers in square centimetres and correct to one decimal place.

4.

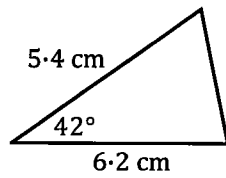

5.

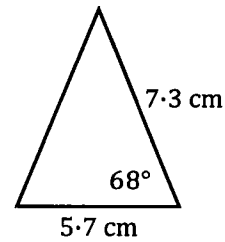

6.

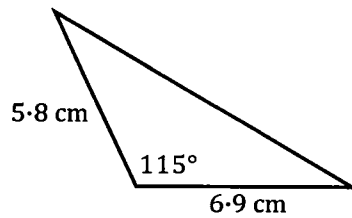

7.

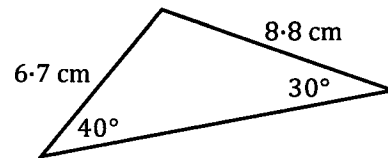

8.

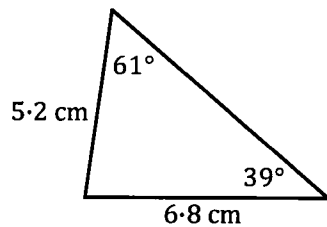

9.

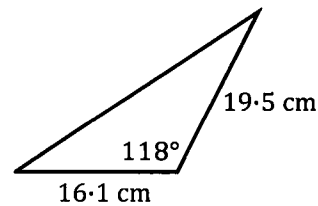

Find the value of  $x$ , correct to one decimal place, in each of the following given that the area of each triangle is as stated. (The diagrams are not necessarily drawn to scale.)

10.

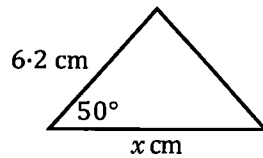

Area =  $20.7 \text{ cm}^2$

11.

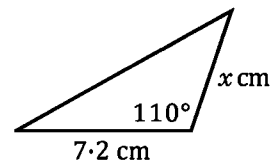

Area =  $20.0 \text{ cm}^2$

12.

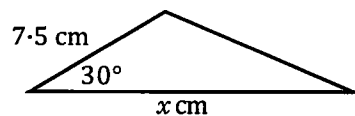

Area =  $15.0 \text{ cm}^2$

13.

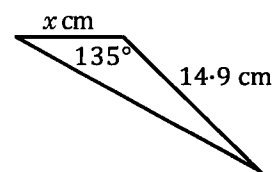

Area =  $45.1 \text{ cm}^2$

14.

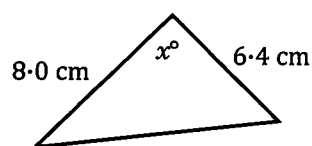

Area =  $25.5 \text{ cm}^2$

15.

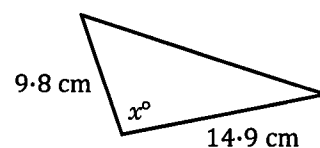

Area =  $72.7 \text{ cm}^2$

**The sine rule.**

Consider a triangle ABC as shown below left for an acute angled triangle and below right for an obtuse angled triangle.

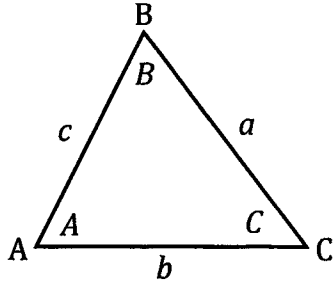

Drawing the perpendicular from B to meet AC at D:

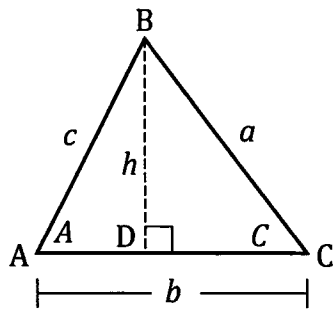

From  $\triangle ABD$ :  $\sin A = \frac{h}{c}$   
 $\therefore h = c \sin A$  ①

From  $\triangle CBD$ :  $\sin C = \frac{h}{a}$   
 $\therefore h = a \sin C$  ②

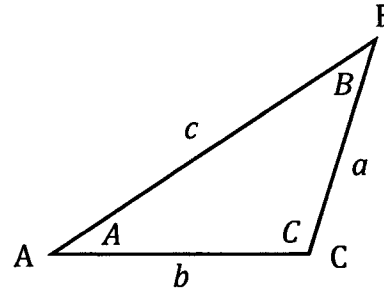

Drawing the perpendicular from B to meet AC produced at D:

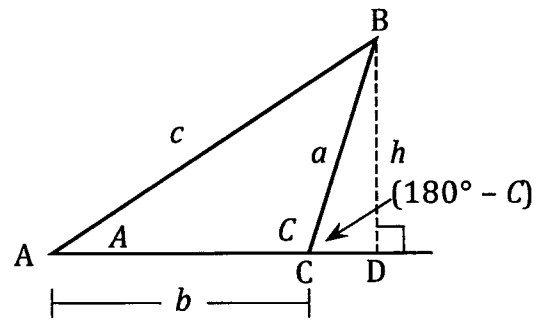

From  $\triangle ABD$ :  $\sin A = \frac{h}{c}$   
 $\therefore h = c \sin A$  ①

From  $\triangle CBD$ :  $\sin (180^\circ - C) = \frac{h}{a}$   
 $\therefore h = a \sin C$  ②

Thus for both the acute triangle and the obtuse triangle:

From ① & ②  $c \sin A = a \sin C$

Thus  $\frac{c}{\sin C} = \frac{a}{\sin A}$  ③

If instead we draw the perpendicular from A to BC we obtain

$\frac{b}{\sin B} = \frac{c}{\sin C}$  ④

From ③ and ④ it follows that

$$\frac{a}{\sin A} = \frac{b}{\sin B} = \frac{c}{\sin C}$$

This is the sine rule.

Rather than learning this formula notice the pattern:  
**Any side on the sine of the opposite angle is equal to any other side on the sine of its opposite angle.**



**Example 4**Find the value of  $x$  in the following.

(a)

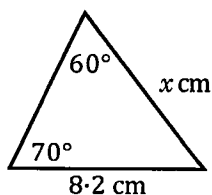

(b)

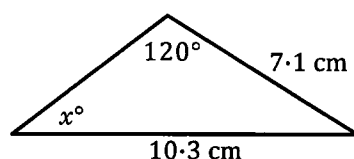

(a) By the sine rule

$$\frac{x}{\sin 70^\circ} = \frac{8.2}{\sin 60^\circ}$$

Multiply by  $\sin 70^\circ$  to isolate  $x$ 

$$x = \frac{8.2 \sin 70^\circ}{\sin 60^\circ}$$

$$= 8.9 \text{ (to 1 dp)}$$

Or, using the "solve" ability of some calculators:

$$\text{solve} \left( \frac{x}{\sin(70)} = \frac{8.2}{\sin(60)}, x \right)$$

$$\{x = 8.897521316\}$$

(b) By the sine rule

$$\frac{10.3}{\sin 120^\circ} = \frac{7.1}{\sin x^\circ}$$

Multiply by  $(\sin x^\circ)(\sin 120^\circ)$ 

$$10.3 \sin x^\circ = 7.1 \sin 120^\circ$$

$$\therefore x \approx 36.7 \text{ (to 1 dp)}$$

$$\text{solve} \left( \frac{10.3}{\sin(120)} = \frac{7.1}{\sin(x)}, x \right) \mid 0 \leq x \leq 180$$

$$\{x = 143.346877, x = 36.65312298\}$$

Note • In part (b) we say  $x = 36.7$  (to 1 dp) despite there being another value of  $x$  between 0 and 180 for which  $10.3 \sin x^\circ = 7.1 \sin 120^\circ$ , i.e.  $x = 180 - 36.7$ , as the calculator shows when asked for solutions in the interval  $0 \leq x \leq 180$ . However, in the given triangle,  $x$  cannot be 143.3 because the triangle already has one obtuse angle and cannot have another. However we will not always be able to dismiss this other value as part (a) of the next example shows.

- Some calculator programs and internet websites allow the user to put in the known sides and angles of a triangle and, provided the information put in is sufficient, the program will determine the remaining sides and angles. Some calculators allow us to create a scale drawing of the triangle and find lengths and angles that way.

These programs can be useful and are worth exploring but make sure that you understand the underlying idea of the sine rule (and the cosine rule which we will see later in this chapter) and can demonstrate the appropriate use of these rules when required to do so.

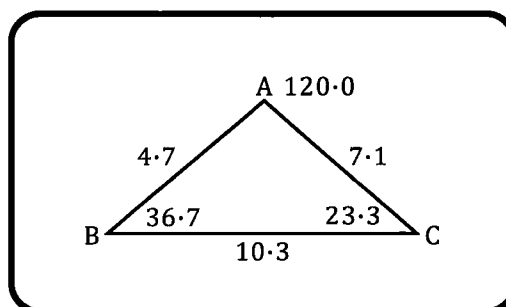

**Example 5**

 Find the value of  $x$  in the following.

(a)

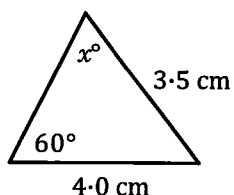

(b)

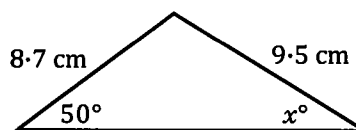

(a) By the sine rule

$$\frac{4.0}{\sin x^\circ} = \frac{3.5}{\sin 60^\circ}$$

 Multiply by  $(\sin x^\circ)(\sin 60^\circ)$ 

$$4.0 \sin 60^\circ = 3.5 \sin x^\circ$$

$$\therefore \sin x^\circ = \frac{4.0 \sin 60^\circ}{3.5}$$

$$x \approx 81.8 \text{ or } 98.2, \text{ both}$$

of which are possible for the given information.

Or, using the "solve" ability of a calculator:

$$\text{solve} \left( \frac{4}{\sin(x)} = \frac{3.5}{\sin(60)}, x \right) \mid 0 \leq x \leq 180$$

$$\{x = 81.7867893, x = 98.2132107\}$$

 (b) (Note that  $x^\circ$ , being opposite a side of length 8.7 cm, must be less than the  $50^\circ$  which is opposite a side of length 9.5 cm.)

By the sine rule

$$\frac{9.5}{\sin 50^\circ} = \frac{8.7}{\sin x^\circ}$$

 Multiply by  $(\sin 50^\circ)(\sin x^\circ)$ 

$$9.5 \sin x^\circ = 8.7 \sin 50^\circ$$

$$\therefore \sin x^\circ = \frac{8.7 \sin 50^\circ}{9.5}$$

$$\text{Thus } x \approx 44.6$$

$$\text{solve} \left( \frac{9.5}{\sin(50)} = \frac{8.7}{\sin(x)}, x \right) \mid 0 \leq x \leq 180$$

$$\{x = 135.4496775, x = 44.55032253\}$$

Note that example 5 part (a) is similar to example 3 part (b) in that there are two triangles that fit the given information. We need to be alert to the possibility of this second solution when the sine rule leads to an equation that is of the form  $\sin x = c$ . However note also that in part (b) we could dismiss the obtuse angled solution because  $x$  had to be smaller than 50. (Or, had we not noticed this from the side lengths, we would reject the obtuse angle as the angle sum of the triangle would exceed  $180^\circ$ )

Example 5(a) is an example of the "ambiguous case" that can arise when using the sine rule. The two triangles that fit the given information are shown below.

 In  $\triangle ABC_1$ .

 Angle A =  $60^\circ$ , AB = 4.0 cm and  $BC_1 = 3.5$  cm.

 In  $\triangle ABC_2$ .

 Angle A =  $60^\circ$ , AB = 4.0 cm and  $BC_2 = 3.5$  cm.

 In  $\triangle ABC_1$ , angle  $AC_1B \approx 98.2^\circ$ .

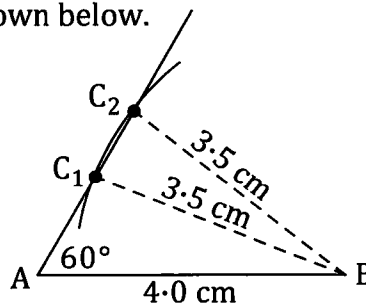
 In  $\triangle ABC_2$ , angle  $AC_2B \approx 81.8^\circ$ .

**The cosine rule.**

Again consider a triangle ABC as shown below left for an acute angled triangle and below right for an obtuse angled triangle.

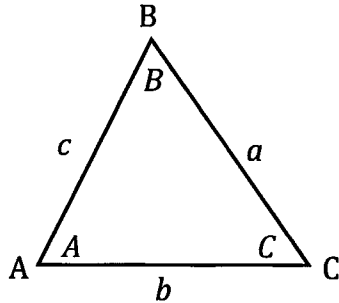

Again we draw the perpendicular from B to meet AC at D:

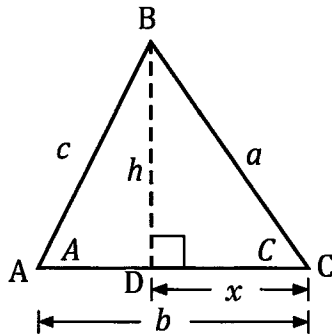

From  $\triangle CBD$ :  $a^2 = h^2 + x^2$  ①

From  $\triangle ABD$ :  $c^2 = h^2 + (b-x)^2$   
 i.e.  $c^2 = h^2 + b^2 + x^2 - 2bx$

Using ①:  $c^2 = a^2 + b^2 - 2bx$  ②

From  $\triangle CBD$ :  $\cos C = \frac{x}{a}$

$\therefore x = a \cos C$  ③

Using ② and ③:  
 $c^2 = a^2 + b^2 - 2ab \cos C$

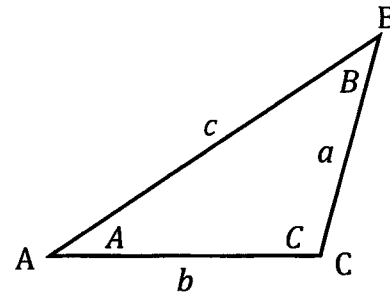

Again we draw the perpendicular from B to meet AC produced at D:

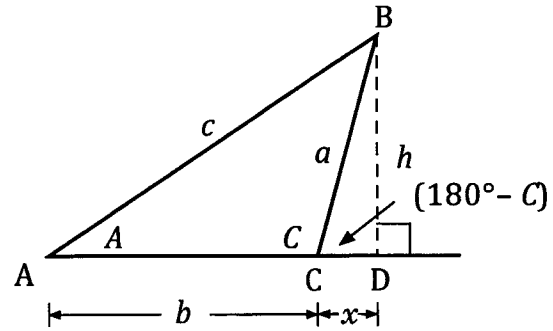

From  $\triangle CBD$ :  $a^2 = h^2 + x^2$  ①

From  $\triangle ABD$ :  $c^2 = h^2 + (b+x)^2$   
 i.e.  $c^2 = h^2 + b^2 + x^2 + 2bx$

Using ①:  $c^2 = a^2 + b^2 + 2bx$  ②

From  $\triangle CBD$ :  $\cos (180^\circ - C) = \frac{x}{a}$

$\therefore x = -a \cos C$  ③

Using ② and ③:  
 $c^2 = a^2 + b^2 - 2ab \cos C$

Thus for both the acute triangle and the obtuse triangle  $c^2 = a^2 + b^2 - 2ab \cos C$ .

This is **the cosine rule**:

$$c^2 = a^2 + b^2 - 2ab \cos C$$

Similarly

$$a^2 = b^2 + c^2 - 2bc \cos A$$

and

$$b^2 = a^2 + c^2 - 2ac \cos B$$

As was said with the sine rule, rather than learning the rule as a formula instead notice the pattern of what it is telling you:

➔ The square of any side of a triangle is equal to the sum of the squares of the other two sides take away twice the product of the other two sides multiplied by the cosine of the angle between them. ➔

**Example 6**

Find the value of  $x$  for the triangle shown sketched on the right.

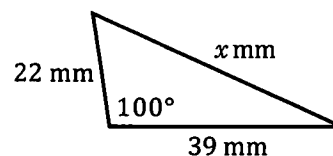

By the cosine rule:

$$\begin{aligned}x^2 &= 22^2 + 39^2 - 2(22)(39)\cos 100^\circ \\ &\approx 2302.98 \\ x &= 48 \text{ to the nearest integer.}\end{aligned}$$

$$\begin{aligned}22^2 + 39^2 - 2 \times 22 \times 39 \times \cos(100) \\ 2302.980273 \\ \sqrt{\text{ans}} \\ 47.98937667\end{aligned}$$

**Example 7**

Find the value of  $x$  for the triangle shown sketched on the right.

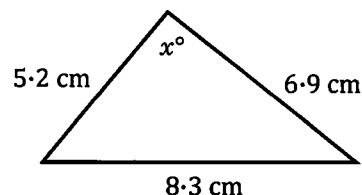

By the cosine rule:

$$\begin{aligned}8.3^2 &= 5.2^2 + 6.9^2 - 2(5.2)(6.9)\cos x^\circ \\ \cos x^\circ &= \frac{5.2^2 + 6.9^2 - 8.3^2}{2(5.2)(6.9)} \\ &\approx 0.08027 \\ x &= 85 \text{ to the nearest integer.}\end{aligned}$$

$$\begin{aligned}\frac{5.2^2 + 6.9^2 - 8.3^2}{2 \times 5.2 \times 6.9} \\ 0.08026755853 \\ \cos^{-1}(\text{ans}) \\ 85.39605483\end{aligned}$$

- Note
- If you prefer to use the solve facility on your calculator make sure you can obtain the same answers as those shown above.
  - In example 7 above there was no need to consider the possibility of a second solution arising, as we had to do when using the sine rule, because if the angle had been obtuse we would have had a negative value for its cosine. An equation of the form  $\cos x = c$  does not have two solutions for  $x$  in the range  $0^\circ$  to  $180^\circ$ .

**Example 8**

The sketch on the right shows a system of three triangles with lengths and angles as indicated. BAE is a straight line. Find the length of CD.

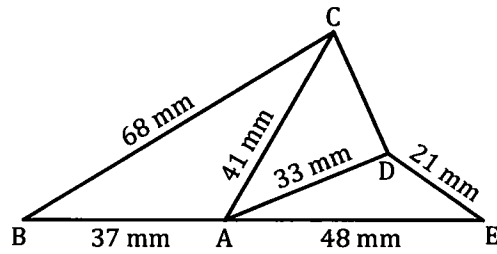

**Thoughts:**  
 CD is one side of  $\triangle ACD$ . In this triangle we know the lengths of AC and AD so if we knew the size of  $\angle CAD$  we could apply the cosine rule to find the length of CD. We can find the size of  $\angle CAD$  if we first find the size of  $\angle CAB$  and the size of  $\angle DAE$ .

For  $\triangle ABC$ , applying the cosine rule:

$$68^2 = 41^2 + 37^2 - 2 \times 41 \times 37 \cos \angle BAC$$

$$\cos \angle BAC = \frac{41^2 + 37^2 - 68^2}{2 \times 41 \times 37}$$

$$\therefore \angle BAC \approx 121.3^\circ$$

$(41^2 + 37^2 - 68^2) \div (2 \times 41 \times 37)$	-0.5187870798
$\cos^{-1}$ Ans	121.2509263
Ans $\rightarrow$ A	121.2509263

For  $\triangle DAE$ , applying the cosine rule:

$$21^2 = 33^2 + 48^2 - 2 \times 33 \times 48 \cos \angle DAE$$

$$\cos \angle DAE = \frac{33^2 + 48^2 - 21^2}{2 \times 33 \times 48}$$

$$\therefore \angle DAE \approx 21.3^\circ$$

$(33^2 + 48^2 - 21^2) \div (2 \times 33 \times 48)$	0.9318181818
$\cos^{-1}$ Ans	21.27996647
Ans $\rightarrow$ B	21.27996647

For  $\triangle CAD$ , applying the cosine rule:

$$CD^2 = 33^2 + 41^2 - 2 \times 33 \times 41 \cos \angle CAD$$

$$\approx 622.3$$

$$\therefore CD \approx 24.9$$

$33^2 + 41^2 - 2 \times 33 \times 41 \cos(180 - A - B)$	622.297976
$\sqrt{\text{Ans}}$	24.94590099

CD is of length 25 mm, to the nearest millimetre.

Notice from the calculator displays that the more accurate values for  $\angle BAC$  and  $\angle DAE$  were stored and later recalled for use, thus avoiding the risk of introducing unnecessary rounding errors.



**Example 9**

Solve the triangle ABC given that AB is of length 6.2 cm, AC is of length 7.1 cm and angle A = 35°.

Note: "Solve the triangle" means to determine all unknown sides and angles.

First make a sketch:

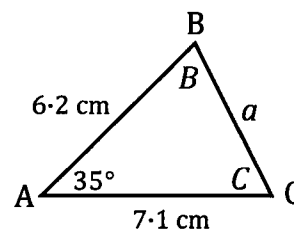

By the cosine rule  $a^2 = 7.1^2 + 6.2^2 - 2(7.1)(6.2) \cos 35^\circ$

$\therefore a \approx 4.09 \text{ cm}$

By the sine rule  $\frac{a}{\sin 35^\circ} = \frac{6.2}{\sin C}$

$\therefore C \approx 60.4^\circ$  (Obtuse angle not applicable – see point below.)

Thus  $B = 180^\circ - (35^\circ + C)$   
 $\approx 84.6^\circ$

In  $\triangle ABC$ ,  $\angle B = 85^\circ$ ,  $\angle C = 60^\circ$  and  $a = 4.1 \text{ cm}$ , all angles to the nearest degree and lengths correct to one decimal place.

**Important point:** In the last example, having used the cosine rule to determine the length of BC we next used the sine rule to find angle C rather than angle B. This was because C, being opposite a smaller side, could not be obtuse. This allowed us to say with confidence that  $C \approx 60.4^\circ$  and we did not have to consider  $(180 - 60.4)^\circ$ .

**Some vocabulary.**

If a question refers to a line **subtending** an angle at a point this is the angle formed by joining each end of the line to the point.

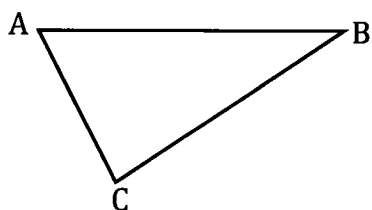

Line AB subtends  $\angle ACB$  at C.

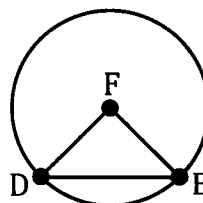

Chord DE subtends  $\angle DFE$  at the centre, F.

If a set of points is referred to as being **collinear** this means they lie in a straight line.

If all four vertices of a quadrilateral lie on the circumference of a circle the quadrilateral is said to be a **cyclic quadrilateral**. One of the properties of cyclic quadrilaterals is that their opposite angles add up to 180°.

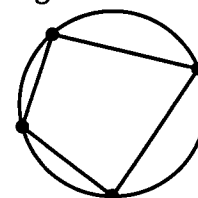

**Exercise 1C**

**The sine rule.**

Find the value(s) of  $x$  in each of the following. (Diagrams not necessarily drawn to scale.)

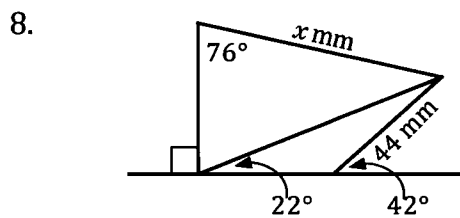
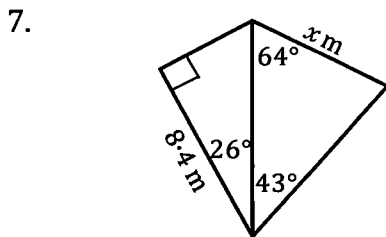
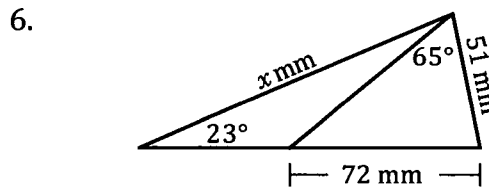
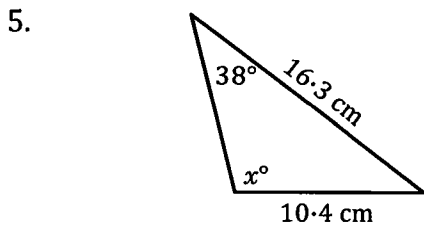
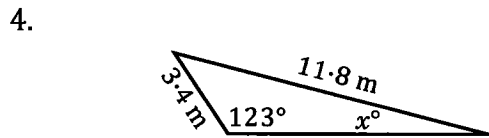
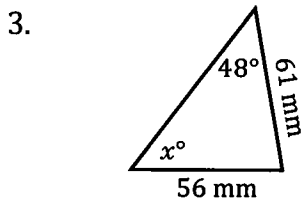
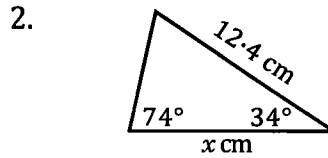
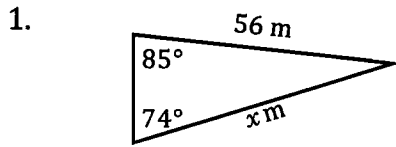

9. The diagram shows a pole  $AB$  with end  $A$  fixed on horizontal ground and the pole supported by a wire attached to end  $B$  and to a point  $C$  on the ground with  $AC = 420$  centimetres. The pole makes an angle of  $50^\circ$  with the ground and the wire makes an angle of  $30^\circ$  with the ground, as shown in the diagram. The points  $A$ ,  $B$  and  $C$  all lie in the same vertical plane. Find the length of the pole giving your answer to the nearest centimetre.

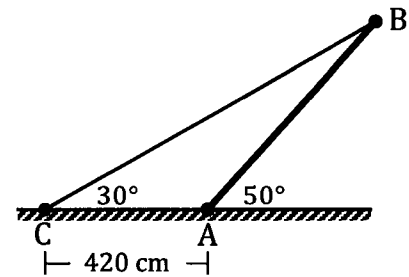



10. Rather than risking the direct shot over a lake a golfer prefers to take two shots to get to the green as shown in the diagram on the right.  
How much further is this two shot route than the direct route?

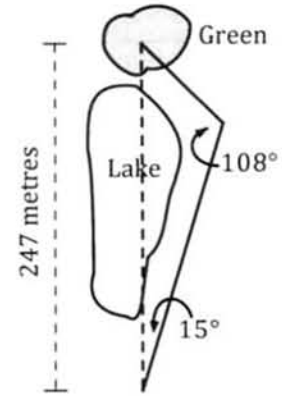

**The cosine rule.**

Find the value of  $x$  in each of the following. (Diagrams not necessarily drawn to scale.)  
When  $x$  involves an angle give your answer to the nearest whole number.  
When  $x$  involves a length give an accuracy consistent with the given lengths.

11.

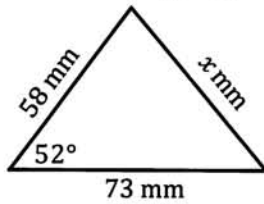

12.

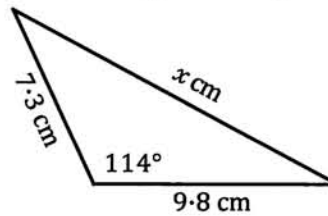

13.

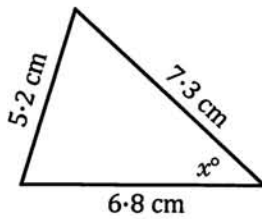

14.

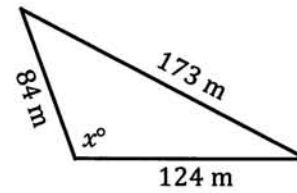

15.

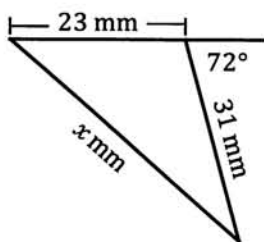

16.

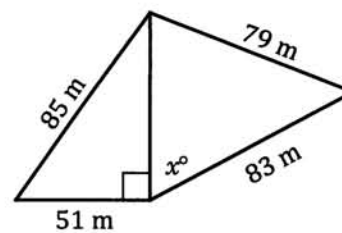

17.

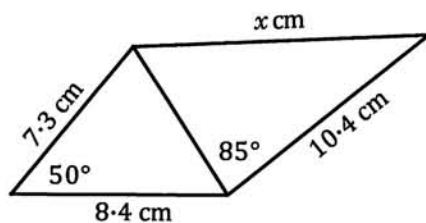

18.

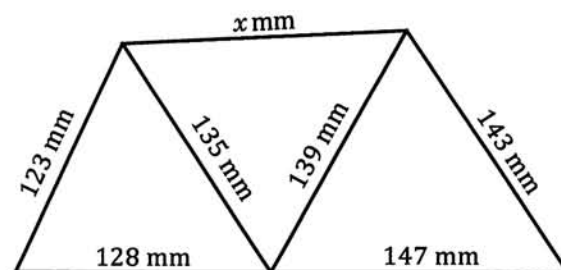

19. A boat travels 6.3 km due North and then turns  $17^\circ$  towards the West and travels a further 7.2 km. How far is it then from its initial position?

20. Jim and Toni leave the same point at the same time with Jim walking away at a speed of 1.4 m/s and Toni at a speed of 1.7 m/s, the two directions of travel making an angle of  $50^\circ$  with each other. If they both continue on these straight line paths how far are they apart after 8 seconds?

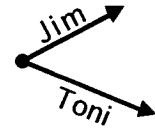

**Miscellaneous.**

Find the value of  $x$  in each of the following. (Diagrams not necessarily drawn to scale.)

21.

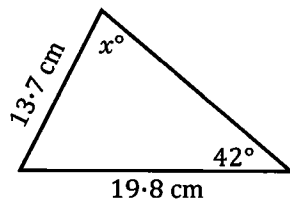

22.

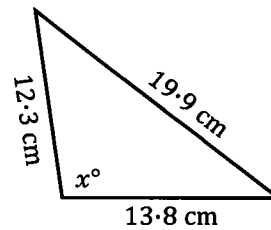

23.

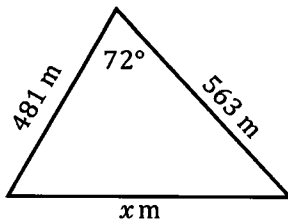

24.

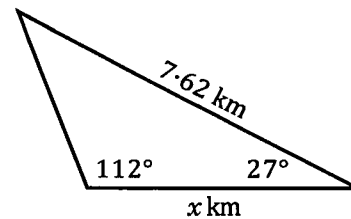

25.

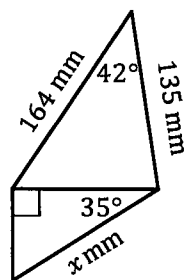

26.

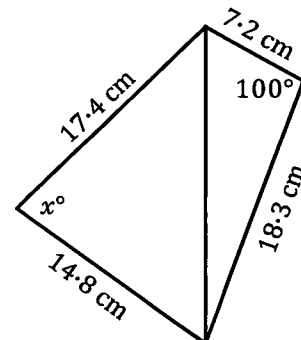

27.

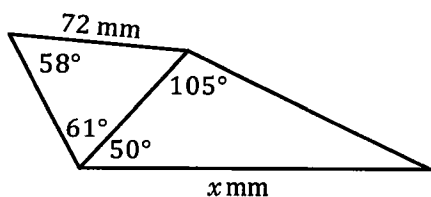

28.

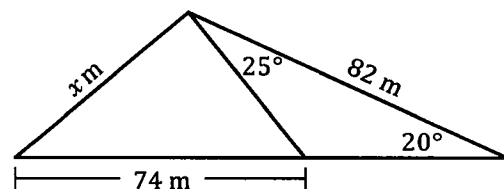

29. The diagram on the right shows a mobile crane used to lift containers from ships and transfer them to waiting container trucks. If  $AB$  is of length 300 centimetres find the lengths of  $AC$  and  $BC$ .

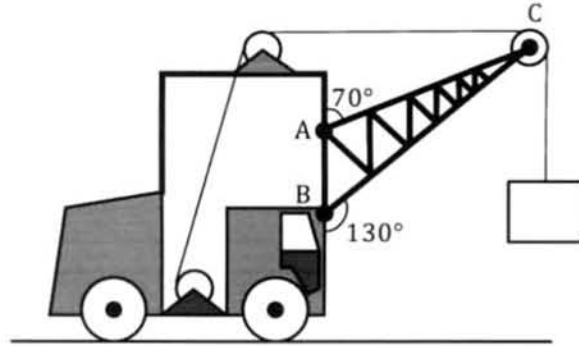

30. A triangle has sides of length 12.7 cm, 11.9 cm and 17.8 cm. Find the size of the smallest angle of the triangle, giving your answer to the nearest degree.
31. In  $\triangle ABC$ ,  $\angle A = 72^\circ$ ,  $b = 7.3$  cm and  $a = 9.1$  cm. Find the length of  $AB$ .
32. Solve  $\triangle ABC$  given that  $\angle A = 43^\circ$ ,  $c = 12.4$  cm and  $b = 14.3$  cm.
33. From a lighthouse, ship A is 15.2 kilometres away on a bearing  $030^\circ$  and ship B is 12.1 kilometres away on a bearing  $100^\circ$ . How far is B from A?
34. From a lighthouse, ship P is 7.3 km away on a bearing  $070^\circ$ . A second ship Q is on a bearing  $150^\circ$  from P and  $130^\circ$  from the lighthouse. How far is Q from the lighthouse?
35. A tower stands vertically at the base of a hill that inclines upwards at  $30^\circ$  to the horizontal. From a point 25 metres from the base of the tower, and directly up the hill, the tower subtends an angle of  $52^\circ$ . Find the height of the tower giving your answer correct to the nearest metre.
36. A parallelogram has sides of length 3.7 cm and 6.8 cm and the acute angle between the sides is  $48^\circ$ .  
Find the lengths of the diagonals of the parallelogram.
37. The diagonals  $AC$  and  $BD$ , of parallelogram  $ABCD$ , intersect at  $E$ .  
If  $\angle AED = 63^\circ$  and the diagonals are of length 10.4 cm and 14.8 cm use the fact that the diagonals of a parallelogram bisect each other to determine the lengths of the sides of the parallelogram.

38. The tray of the tip truck shown on the right is tipped by the motor driving rod  $BC$  clockwise about  $B$ . As the tray tips end  $C$  moves along the guide towards  $A$ . If  $AB = 2$  metres and  $BC = 1$  metre find the size of  $\angle CAB$  when  $AC$  is  
(a) 2.6 metres, (b) 2.1 metres.

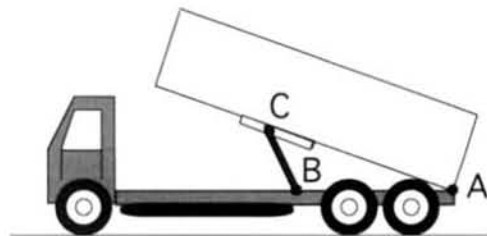

39. The "W-type roof truss" shown on the right is to be constructed with  $AE = 900$  cm and  $AG = GF = FE$ .  $\angle DEF = 20^\circ$ ,  $ED = DC$  and the truss is symmetrical with the vertical line through C as the line of symmetry.

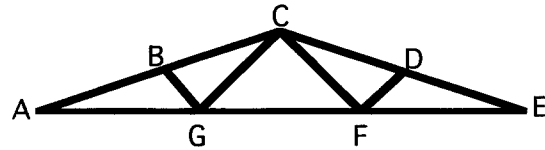

Calculate the following lengths, correct to the nearest cm  
 (a) CE, (b) ED, (c) DF, (d) CF.

40. Find, to the nearest millimetre, the distance between the tip of the 70 mm hour hand and the tip of the 90 mm minute hand of a clock at (a) 5 o'clock, (b) 10 minutes past 5.

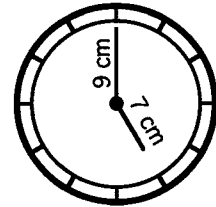

41. A coastal observation position is known to be 2.50 km from a lighthouse. The coastguard in the observation position is in radio and visual contact with a ship in distress at sea. If the coastguard looks towards the lighthouse and then towards the ship these two directions make an angle of  $40^\circ$  with each other. If the captain on the ship looks towards the observation position and then towards the lighthouse these two directions make an angle of  $115^\circ$  with each other. (The ship, the lighthouse and the observation position may all be assumed to be on the same horizontal level.)

How far is the ship from (a) the lighthouse, (b) the coastal observation position?

42. Do the following question twice, once using Pythagoras and the cosine rule and once using right triangle trigonometry.

Find, to the nearest degree, the size of the largest of the three angles of  $\triangle ABC$  where A, B and C have coordinates A (6, 2), B (2, 5), C (-6, -3).

43. A, B and C are three collinear points on level ground with B between A and C. The distance from A to B is 40 m. A vertical tower, CD, has its base at C. From A and B the top of the tower, point D, has angles of elevation of  $20^\circ$  and  $35^\circ$  respectively. Find the height of the tower.

44. Points A, B and C all lie on the same horizontal ground with B due North of A and C on a bearing of  $030^\circ$  from A.

From the top of a vertical tower at A, 37 metres above ground, point B has an angle of depression of  $17^\circ$  and point C has an angle of depression of  $12^\circ$ .

How far is B from C?

45. Solve  $\triangle GHI$  given that  $\angle G = 55^\circ$ ,  $i = 19.4$  cm and  $g = 18.2$  cm.
46. Points A, B and C lie on horizontal ground. From A the bearings of B and C are  $330^\circ$  and  $018^\circ$  respectively. A vertical tower of height 40 m has its base at A. From B and C the angles of elevation of the top of the tower are  $20^\circ$  and  $12^\circ$  respectively. How far is B from C, to the nearest metre?
47. ABCD is a cyclic quadrilateral with  $\angle DAB = 100^\circ$ ,  $AB = 7.2$  cm,  $AD = 6.1$  cm and  $BC = 8.2$  cm. Find (a) the size of  $\angle BCD$ ,  
(b) the size of  $\angle ADC$ ,  
(c) the perimeter of the quadrilateral,  
(d) the area of the quadrilateral.
48. ABCD is a cyclic quadrilateral with  $AB = 10$  cm,  $BC = 12$  cm,  $CD = 9$  cm,  $DA = 14$  cm. If  $\angle ABC = \theta$ ,  $\angle ADC = \phi$  and AC is of length  $x$  cm.  
(a) find an expression for  $x^2$  in terms of  $\cos \theta$ ,  
(b) find an expression for  $x^2$  in terms of  $\cos \phi$ ,  
(c) find  $\theta$  in degrees correct to the nearest degree.
49. Make use of the cosine rule, and the rule for the area of a triangle given two sides and the included angle, to determine the area of a triangular block of land with sides of length 63 m, 22 m and 55 m and then check that your answer agrees with the following statement (known as Heron's rule):  
The area of a triangle with sides of length  $a$ ,  $b$  and  $c$  is given by:

$$\text{Area} = \sqrt{s(s-a)(s-b)(s-c)} \quad \text{where } s = \frac{a+b+c}{2}.$$

50. A triangular building block has sides of length 25 metres, 48 metres and 53 metres. A second triangular block has sides of length 33 metres, 38 metres and 45 metres. Which block has the greater area and by how much (to the nearest square metre)?

### Regular polygons.

Suppose that a regular  $n$ -sided polygon has all of its vertices touching the circumference of a circle of radius 1 unit.

For  $n = 5, 6, 7$  and  $8$  this is shown below:

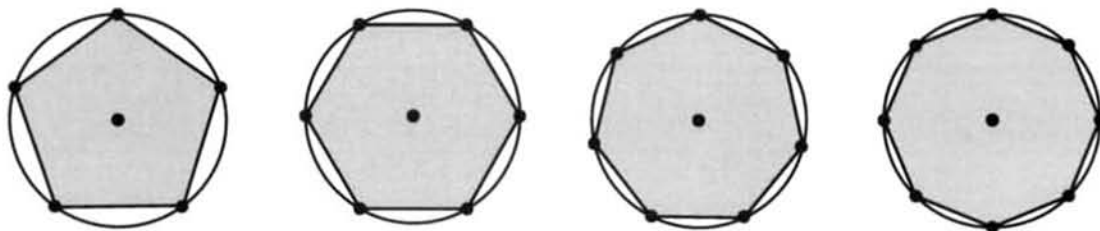

Find the area of each of the above polygons and investigate this situation for increasing integer values of  $n$ .

**Exact values.**

It can sometimes be the case that a mathematician is asked to solve an equation and, not knowing for what purpose the answer is required, is not sure to what degree of accuracy the answer should be given. To avoid having to make this decision regarding accuracy the mathematician may choose to leave the expression as an **exact value**. Others can then use this exact value to whatever degree of accuracy they require.

For example, suppose we were asked to solve the equation:  $x^2 - 1 = 5$   
 Rather than deciding to give the answer to, say, 2 decimal places  $x = \pm 2.45$   
 we could instead give the answer in *exact* form:  $x = \pm \sqrt{6}$

In trigonometry, commonly used exact values are the trigonometrical ratios of  $0^\circ$ ,  $30^\circ$ ,  $45^\circ$ ,  $60^\circ$  and  $90^\circ$ .

Indeed some calculators, when set to "exact mode", will not give the approximate decimal value for  $\sin 60^\circ$ ,  $\cos 45^\circ$ ,  $\tan 30^\circ$  etc., but will instead give the exact values.

$\sin(60)$	$\frac{\sqrt{3}}{2}$
$\cos(45)$	$\frac{\sqrt{2}}{2}$
$\tan(30)$	$\frac{\sqrt{3}}{3}$

**Question:** If it was not for this calculator display how would we know the exact value for  $\sin 60^\circ$ ?

**Answer:** These exact values can be obtained by considering a number of specific triangles, as shown below.

The exact values for  $30^\circ$  and  $60^\circ$  can be obtained by considering an equilateral triangle ABC of side 2 units, as shown on the right.

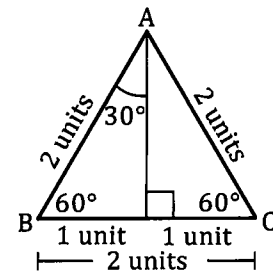

Note that the perpendicular from A to BC will bisect BC and, by Pythagoras, will be of length  $\sqrt{3}$  units.

It then follows that:

$$\begin{aligned} \sin 30^\circ &= \frac{1}{2} & \cos 30^\circ &= \frac{\sqrt{3}}{2} & \tan 30^\circ &= \frac{1}{\sqrt{3}} \\ \sin 60^\circ &= \frac{\sqrt{3}}{2} & \cos 60^\circ &= \frac{1}{2} & \tan 60^\circ &= \frac{\sqrt{3}}{1} \end{aligned}$$

Notice that whilst the above statement gives the exact value of  $\tan 30^\circ$  as  $\frac{1}{\sqrt{3}}$  the calculator shows this same value as  $\frac{\sqrt{3}}{3}$ , adopting the conventional style of displaying such values with denominators free of square roots (i.e. with a **rational** denominator).



The exact values for  $45^\circ$  can be obtained from the diagram on the right showing an isosceles, right triangle DEF. Note that DE and EF are each of unit length and so, by Pythagoras, DF will be of length  $\sqrt{2}$  units.

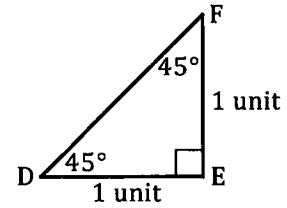

Hence:  $\sin 45^\circ = \frac{1}{\sqrt{2}}$        $\cos 45^\circ = \frac{1}{\sqrt{2}}$        $\tan 45^\circ = \frac{1}{1}$

The exact values for  $0^\circ$  and  $90^\circ$  can be obtained by considering the triangle GHI on the right. If point G is brought closer and closer to H, angle G will approach  $90^\circ$  and angle I will approach  $0^\circ$ . If IH is of unit length then, as angle G approaches  $90^\circ$ , IG will approach unit length and GH will approach zero length.

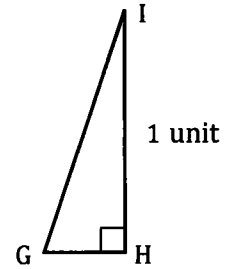

$\sin 0^\circ = \frac{0}{1}$        $\cos 0^\circ = \frac{1}{1}$        $\tan 0^\circ = \frac{0}{1}$   
 $\sin 90^\circ = \frac{1}{1}$        $\cos 90^\circ = \frac{0}{1}$        $\tan 90^\circ = \frac{1}{0}$

These exact values are summarised in the following table:

	$0^\circ$	$30^\circ$	$45^\circ$	$60^\circ$	$90^\circ$
Sine	0	$\frac{1}{2}$	$\frac{1}{\sqrt{2}}$	$\frac{\sqrt{3}}{2}$	1
Cosine	1	$\frac{\sqrt{3}}{2}$	$\frac{1}{\sqrt{2}}$	$\frac{1}{2}$	0
Tangent	0	$\frac{1}{\sqrt{3}}$	1	$\sqrt{3}$	undefined

The reader is encouraged to learn these exact values and should be able to write them down without reference to the table.

The reader should also be able to determine exact values for the sine, cosine and tangent of a number of obtuse angles by making use of the following facts:

$\sin \theta = \sin (180^\circ - \theta)$        $\cos \theta = -\cos (180^\circ - \theta)$        $\tan \theta = -\tan (180^\circ - \theta)$

the last of these three statements following from the fact that  $\tan \theta = \frac{\sin \theta}{\cos \theta}$ .

**Exercise 1D**

Without looking back at the table on the previous page try to write down the exact values of the following and then check each one using a calculator.

- |                      |                      |                      |                      |
|----------------------|----------------------|----------------------|----------------------|
| 1. $\sin 0^\circ$    | 2. $\sin 30^\circ$   | 3. $\tan 45^\circ$   | 4. $\sin 60^\circ$   |
| 5. $\cos 60^\circ$   | 6. $\cos 0^\circ$    | 7. $\tan 90^\circ$   | 8. $\cos 45^\circ$   |
| 9. $\cos 30^\circ$   | 10. $\tan 60^\circ$  | 11. $\sin 90^\circ$  | 12. $\tan 0^\circ$   |
| 13. $\cos 60^\circ$  | 14. $\sin 45^\circ$  | 15. $\tan 30^\circ$  | 16. $\sin 120^\circ$ |
| 17. $\cos 135^\circ$ | 18. $\cos 150^\circ$ | 19. $\cos 120^\circ$ | 20. $\cos 180^\circ$ |
| 21. $\tan 135^\circ$ | 22. $\tan 120^\circ$ | 23. $\tan 150^\circ$ | 24. $\tan 180^\circ$ |
| 25. $\sin 180^\circ$ | 26. $\sin 150^\circ$ | 27. $\sin 135^\circ$ |                      |

Find the **exact** value of  $x$  in each of the following.

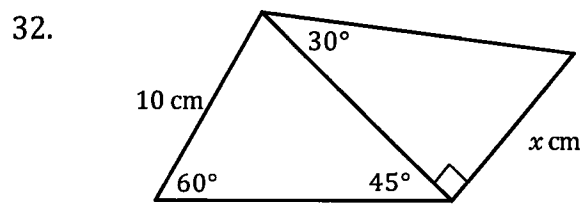
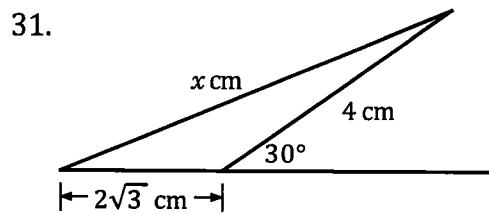
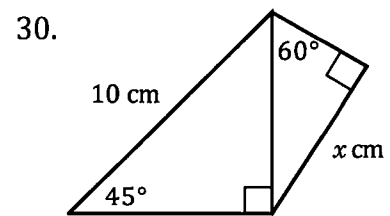
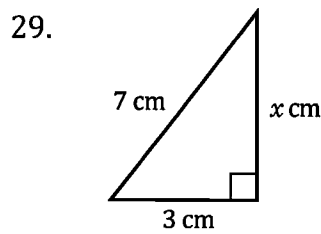
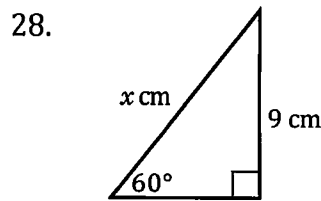

33. For the diagram shown on the right prove that

$$y = \frac{4\sqrt{2}(x)\sin\theta}{3}$$

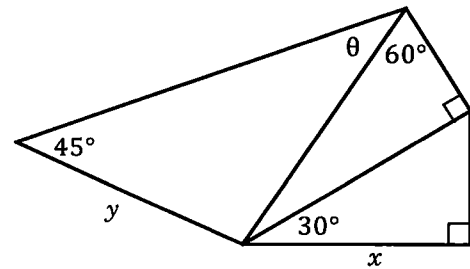

34. For the diagram shown on the right prove that

$$y = \frac{4\sin\theta}{\sin\phi}$$

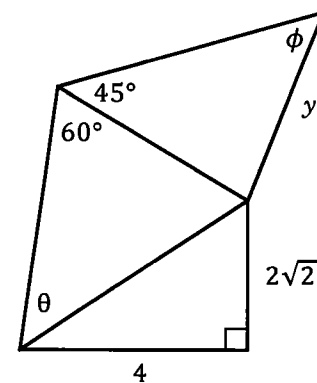

**The angle of inclination of a line.**

The *angle of inclination of a line* is the angle from  $0^\circ$  to  $180^\circ$  that the line makes with the *x*-axis, measured from the *x*-axis, anticlockwise.

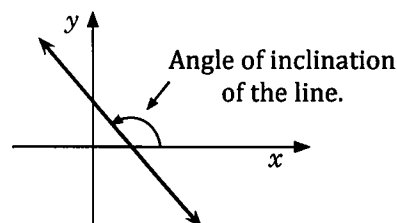
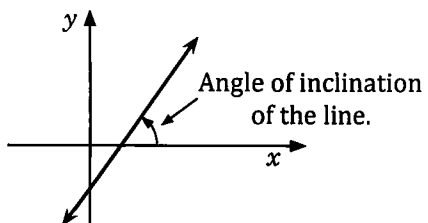

**Exercise 1E**

For each of the lines shown below

- (a) write down the angle of inclination of the line,
- (b) determine the gradient of the line as an exact value. (Think about it.)

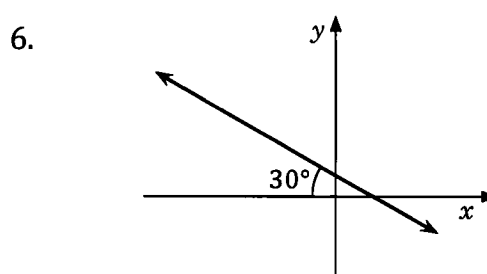
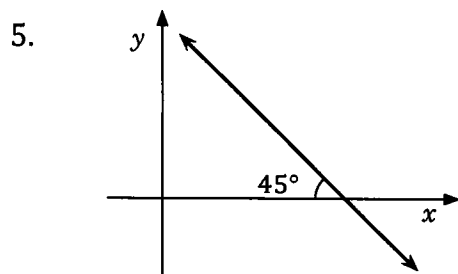
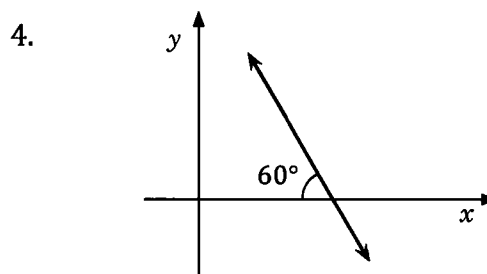
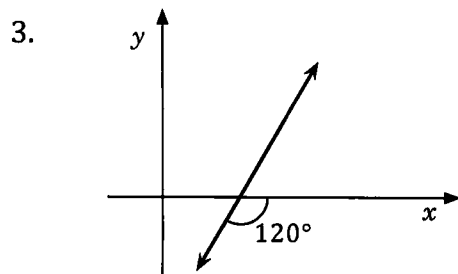
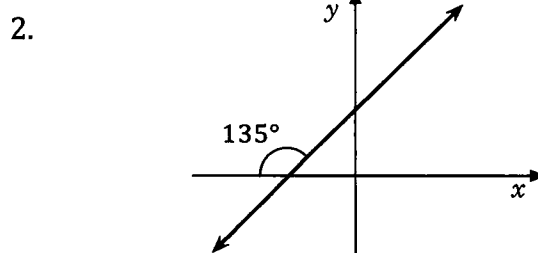
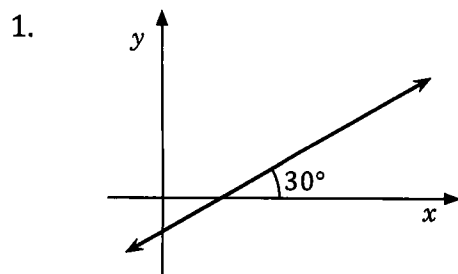

7. What is the relationship between the angle of inclination of a line and the gradient of that line?

**Miscellaneous Exercise One.**

**This miscellaneous exercise may include questions involving the work of this chapter and the ideas mentioned in the preliminary work section at the beginning of the book.**

1. Expand and simplify:

(a)  $2(3x + 4) + 5(x - 3)$

(c)  $5 + 2(5x - 4)$

(e)  $2(3 - 4x) + 5(3x + 1)$

(g)  $(x + 3)(x + 5)$

(i)  $(2x + 5)(x + 3)$

(b)  $2(3x + 4) - 5(x - 3)$

(d)  $5 - 2(5x - 4)$

(f)  $2(3 - 4x) - 5(3x + 1)$

(h)  $(x + 3)(x - 5)$

(j)  $(2x - 5)(x - 3)$

2. Factorise each of the following:

(a)  $2x + 8$

(c)  $16ab + 12ac + 8a^2$

(e)  $x^2 + 7x - 8$

(g)  $x^2 + 5x - 14$

(i)  $x^2 - 16$

(b)  $6y + 9$

(d)  $a^2 + a$

(f)  $x^2 - 9x + 8$

(h)  $x^2 - 8x + 12$

(j)  $2a^2 - 18$

3. Simplify each of the following.

(a)  $\sqrt{20}$

(b)  $\sqrt{45}$

(c)  $\sqrt{200}$

(d)  $3\sqrt{5} \times 2\sqrt{5}$

(e)  $\sqrt{15} \times \sqrt{3}$

(f)  $6\sqrt{3} \times \sqrt{6}$

(g)  $3\sqrt{5} \times 7\sqrt{2}$

(h)  $(3\sqrt{2} + 1)^2$

4. A ladder stands with its base on horizontal ground and its top against a vertical wall. When the base of the ladder is  $a$  metres from the wall the ladder makes an angle of  $80^\circ$  with the ground. When the base of the ladder is pulled a further 20 cm from the wall the angle made with the ground becomes  $75^\circ$ . Find  $a$  (correct to 2 decimal places) and the length of the ladder (correct to the nearest centimetre).

5. From a lighthouse, ship A is 6.2 kilometres away on a bearing  $040^\circ$  and ship B is 10.8 km away on a bearing  $100^\circ$ . Find the distance and bearing of A from B.

6. When the radius,  $r$ , of a circle increases then both the circumference,  $C$ , of the circle and the area,  $A$ , of the circle also increase. Does this mean that both  $C$  and  $r$ , and  $A$  and  $r$ , are in direct proportion.

7. Ignoring any wastage needed for cutting, joining etc., what total length of steel would be needed to make twelve of the steel frameworks shown sketched on the right, rounding your answer up to the next ten metres.

